

INSTALLATION INSTRUCTIONS

DESCRIPTION: Kickstand Removal Kit
PART NUMBER: B91-F73A0-V0
MODEL: '15~ WR250F, '12~ WR450F,
'15~ YZ250FX, '16~ YZ450FX



⚠ WARNING

Please read and understand these instructions completely before installation to avoid possible injury, or damage to the accessory or vehicle.

NOTICES:

This installation requires a torque wrench and should be performed by an authorized Yamaha dealer or other qualified technician.

WARRANTY INFORMATION:

Genuine Yamaha Accessories are covered by a one-year limited warranty against defects in material or workmanship. Labor for replacement of defective components is not covered. See your Yamaha dealer for a copy of the warranty statement.

DEALER OR INSTALLER:

These instructions contain important information for future reference and *must* be given to the customer.

PARTS LIST:

No.	Part Number	Description	Qty
--	B91-F73A0-V0	Kickstand Removal Kit	--
①	*	Footpeg Mount	1
②	*	Roller Bolt	1
③	*	Cotter Pin	1

*All parts are available separately. See your Yamaha dealer for part numbers and to order individually.

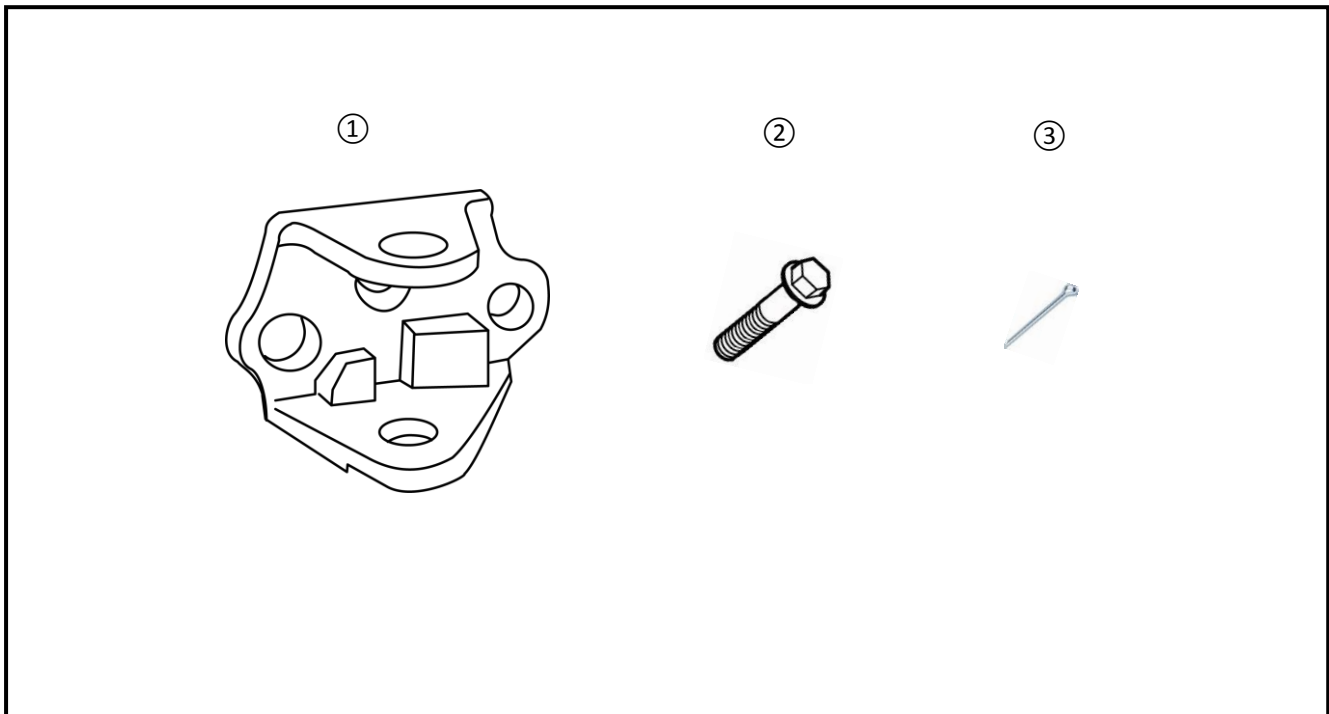

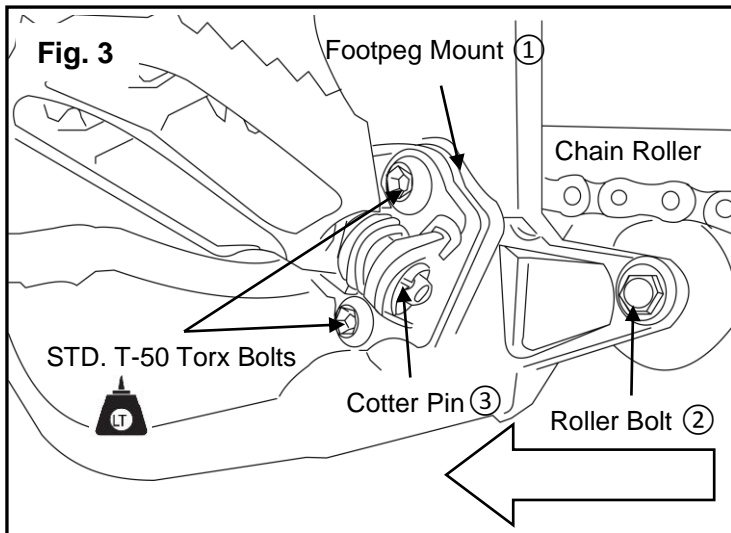
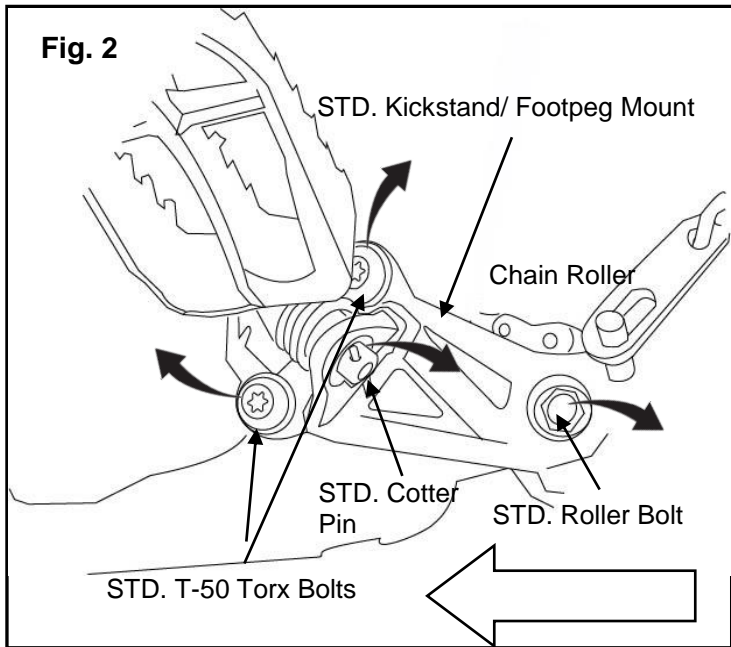
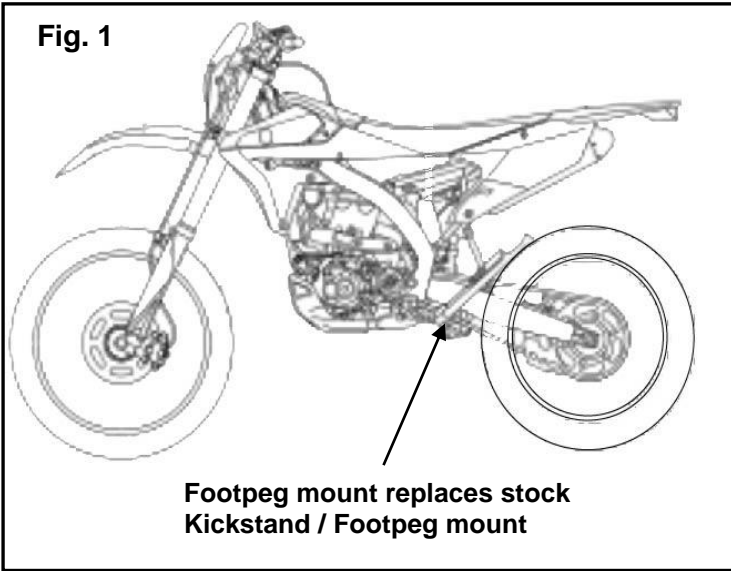

PREPARATION:

- Stand motorcycle on a secure and level surface.
- Clean mounting surfaces before installation.

INSTALLATION:

Kickstand Dis-assembly

1. Remove the bolt, collar, washer, and nut that hold the lower chain roller to the Kickstand / Footpeg mount. The roller, collar, nut, and washer will be reused – the bolt will not.
2. Remove 2 Torx® T-50 bolts that hold the left foot peg / kickstand mount plate to the frame (Fig.2) retain T-50 bolts.
3. Remove the cotter pin from the stock / kickstand assembly. Retain the washer, mount post, spring, and foot peg. The kickstand / footpeg mount will not be reused.
4. Install the Roller Bolt ② through the frame, roller, washer, and into the stock nut. Take care to position the stock collar inside the chain roller. Torque the nut on the Roller Bolt to 16Nm (12 ft-lbf).
5. Apply locking agent Loctite® 268 (ACC-QKSTX-26-80) or equivalent thread locker to the 2 Stock Torx bolts.
6. Torque the Torx bolts to 55Nm (40 lbf-ft).
7. Install the foot peg to the Footpeg Mount ① with the stock Pin, Washer, and new Cotter Pin ③.

MAINTENANCE:

Periodically, check torque on all hardware. If loose hardware is found, re-torque to specification.

CARE AND CLEANING:

Clean parts with a clean soft cloth and mild soap and water. Rinse and dry. Lubricate with Lithium Grease.

CUSTOMER SERVICE:

For further information see your Yamaha dealer.

ESTIMATED TIME TO INSTALL: 0.5 HRS